

Deutsches Institut für Bautechnik

Anstalt des öffentlichen Rechts

Kolonnenstr. 30 L
10829 Berlin
Germany

Tel.: +49(0)30 787 30 0
Fax: +49(0)30 787 30 320
E-mail: dibt@dibt.de
Internet: www.dibt.de

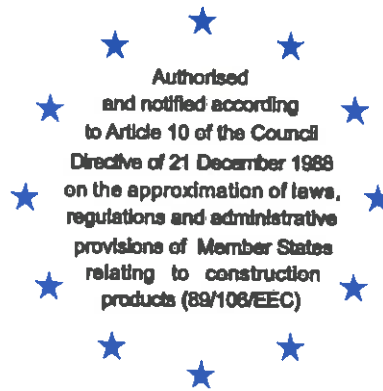

DIBt

Mitglied der EOTA
Member of EOTA

European Technical Approval ETA-05/0001

English translation prepared by DIBt - Original version in German language

Handelsbezeichnung
Trade name

Euromac 2

Zulassungsinhaber
Holder of approval

EUROMAC 2
Parc Industriel de Furst BP B.P. 22
57730 Folschviller
FRANKREICH

Zulassungsgegenstand
und Verwendungszweck

*Generic type and use
of construction product*

Nicht lasttragender verlorener Schalungsbausatz
"EUROMAC 2" bestehend aus EPS-Schalungselementen
*Non-load bearing permanent shuttering kit "Euromac 2" based on
shuttering elements of EPS*

Geltungsdauer:
Validity:

vom
from
bis
to

16 February 2005

16 February 2010

verlängert vom
extended from
bis
to

10 May 2010

10 May 2015

Herstellwerk
Manufacturing plant

EUROMAC 2
Parc Industriel de Furst BP B.P. 22
57730 Folschviller
FRANKREICH

Diese Zulassung umfasst
This Approval contains

21 Seiten einschließlich 9 Anhänge
21 pages including 9 annexes



Europäische Organisation für Technische Zulassungen
European Organisation for Technical Approvals

I LEGAL BASES AND GENERAL CONDITIONS

- 1 This European technical approval is issued by Deutsches Institut für Bautechnik in accordance with:
 - Council Directive 89/106/EEC of 21 December 1988 on the approximation of laws, regulations and administrative provisions of Member States relating to construction products¹, modified by Council Directive 93/68/EEC² and Regulation (EC) N° 1882/2003 of the European Parliament and of the Council³;
 - Gesetz über das In-Verkehr-Bringen von und den freien Warenverkehr mit Bauprodukten zur Umsetzung der Richtlinie 89/106/EWG des Rates vom 21. Dezember 1988 zur Angleichung der Rechts- und Verwaltungsvorschriften der Mitgliedstaaten über Bauprodukte und anderer Rechtsakte der Europäischen Gemeinschaften (Bauproduktengesetz - BauPG) vom 28. April 1998⁴, as amended by law of 31 October 2006⁵;
 - Common Procedural Rules for Requesting, Preparing and the Granting of European technical approvals set out in the Annex to Commission Decision 94/23/EC⁶;
 - Guideline for European technical approval of "Nonload-bearing permanent shuttering systems based on hollow blocks or panels of insulating materials and sometimes concrete", ETAG 009.
- 2 Deutsches Institut für Bautechnik is authorized to check whether the provisions of this European technical approval are met. Checking may take place in the manufacturing plant. Nevertheless, the responsibility for the conformity of the products to the European technical approval and for their fitness for the intended use remains with the holder of the European technical approval.
- 3 This European technical approval is not to be transferred to manufacturers or agents of manufacturers other than those indicated on page 1, or manufacturing plants other than those indicated on page 1 of this European technical approval.
- 4 This European technical approval may be withdrawn by Deutsches Institut für Bautechnik, in particular pursuant to information by the Commission according to Article 5(1) of Council Directive 89/106/EEC.
- 5 Reproduction of this European technical approval including transmission by electronic means shall be in full. However, partial reproduction can be made with the written consent of Deutsches Institut für Bautechnik. In this case partial reproduction has to be designated as such. Texts and drawings of advertising brochures shall not contradict or misuse the European technical approval.
- 6 The European technical approval is issued by the approval body in its official language. This version corresponds fully to the version circulated within EOTA. Translations into other languages have to be designated as such.

1 Official Journal of the European Communities L 40, 11 February 1989, p. 12
2 Official Journal of the European Communities L 220, 30 August 1993, p. 1
3 Official Journal of the European Union L 284, 31 October 2003, p. 25
4 Bundesgesetzblatt Teil I 1998, p. 812
5 Bundesgesetzblatt Teil I 2006, p.2407, 2416
6 Official Journal of the European Communities L 17, 20 January 1994, p. 34

II SPECIFIC CONDITIONS OF THE EUROPEAN TECHNICAL APPROVAL

1 Definition of product and intended use

1.1 Definition of product

The shuttering system "EUROMAC 2" is a non-load-bearing permanent shuttering kit based on shuttering elements (see Annexes 1 and 2) and accessory parts (see Annex 3) applicable as formwork for plain and reinforced concrete walls cast in-situ. The accessory parts are end leaves, lintel bottom leaves and capsules.

1.1.1 Shuttering elements

The shuttering elements consist of one-layered expanded polystyrene (EPS) leaves which are prefabricated in connection with ladders of steel. The ladders consist of two flat steels and spacers of steel wire which connect the flat steels. The horizontal distance between the spacers is 150 mm (see h in Annexes 1 and 2). The spacers are fastened to the flat steels by spot welding. In the finished element the vertical distance between the ladders is 150 mm and the flat steels of the ladders are completely enclosed in the EPS (expanded polystyrene) of the shuttering leaves. Before delivering on site on the outer surfaces of the outer shuttering leave a coating against UV radiation is applied.

The upper and lower surfaces of the shuttering leaves are castellated and the vertical mating surfaces are tongue and groove to form a tight fit when joined together. The outer surfaces have tapered grooves running vertically. At the inner surfaces offset to the grooves ribs are situated which serve as mechanical fixing of the shuttering leaves to the concrete. They also form locks for end stops and lintel elements. The dimensions of the elements range from 1000 mm to 1750 length and from 200 mm to 600 mm height.

The thickness of the inner shuttering leaf in all cases is 45 mm and the thickness of the outer shuttering leaf ranges from 45 to 245 mm. The minimal thickness of concrete core b_{\min} in most cases is 145 mm with a associated maximum thickness of concrete core b_{\max} of 160 mm. There is only one element with a minimum thickness of concrete core b_{\min} of 195 mm and the associated maximum thickness of concrete core b_{\max} of 210 mm (see Annexes 1 and 2).

Special elements are also part of the kit as angular and end elements (see Annex 2) which are produced in the same manner as described above.

1.1.2 Accessory parts

1.1.2.1 End leaves

End leaves are inserted in the gaps between the shuttering leaves at openings of the wall.

1.1.2.2 Lintel bottom leaves

Lintel bottom leaves shall be inserted in the gaps between the shuttering leaves and form the bottom of a shuttering of a lintel. Before concreting the leaves have to be supported.

1.1.2.3 Capsule

The capsule according to Annex 3 are made of plastic. They protect the cutting edges of the flat steels against corrosion and personal injury during construction.

1.2 Intended use

The kit is intended to be used for construction of internal walls as well as external walls above or below ground which are load-bearing (structural) or non load-bearing (non structural), including those which are subjected to fire regulations.

When using this type of construction below ground a waterproofing according to applicable national rules shall be provided depending on whether water not exerting pressure or water exerting pressure is to be dealt with. The waterproofing shall be protected from mechanical damage by a impact resistant protective layer.

The provisions made in this European technical approval are based on an assumed working life of the shuttering kit of at least 50 years, provided that the conditions laid down in sections 4.2, 5.1 and 5.2 for the packaging, transport, storage, installation, use, maintenance and repair are met. The indications given on the working life cannot be interpreted as a guarantee given by the producer, but are to be regarded only as a means for choosing the right products in relation to the expected economically reasonable working life of the works.

2 Characteristics of products and methods of verification

2.1 Characteristics of products

2.1.1 Shuttering elements

The shuttering elements correspond to the information and drawings given in the Annexes 1 to 3. The characteristic data of the standard and special shuttering elements are given in the Tables of Annexes 1 and 2. The kit consists of the following shuttering elements:

- standard shuttering elements (Annex 1)
- end shuttering elements (Annex 2)
- corner shuttering elements (Annex 2)

For the shuttering leaves expanded polystyrene EPS-EN 13163-T1-L1-W2-S2-P4-DS(70,-)3-BS200-CS(10)150-DS(N)5-TR100 made of polystyrene particle foam with a apparent density of 27,5 bis 32 kg/m³ respectively a thermal conductivity $\lambda_d = 0,0329 \text{ W/(m}\cdot\text{K)}$ according to EN 13163 is used.

The material characteristics, dimensions and tolerances of the shuttering elements not indicated in Annex 1 are given in the technical documentation⁷ of the ETA.

2.1.2 Accessory parts

2.1.2.1 End leaves

End leaves are made of the same form and EPS material as the shuttering leaves with a thickness of 70 mm. There are two length of end leaves in dependence of the thickness of concrete core, 160 mm and 210 mm (see Annex 3). The vertical mating surfaces are tongue and groove.

2.1.2.2 Lintel bottom leaves

Lintel bottom leaves are made of the same EPS material as the shuttering leaves with a thickness of 50 mm. There are only lintel bottom leaves for the shuttering elements with a maximum thickness of concrete core (see b_{\max} in Annex 1) of 160 mm. Their width is 160 mm and their length 1 m (see Annex 3). Their vertical surfaces in length direction are shaped in such a way that a form fit to the inner surfaces of the shuttering leaves is possible.

⁷

The technical documentation of the ETA is deposited at DIBt and, as far as relevant for the tasks of the approved bodies involved in the attestation of conformity procedure, is handed over to the approved bodies.

2.1.2.3 Capsule

The capsule according to Annex 3 are made of plastic.

2.2 Methods of verification

2.2.1 General

The assessment of the fitness of the shuttering system for the intended use has been made in compliance with ETAG 009, Guideline for European Technical Approval of "Non load-bearing permanent shuttering kits/systems based on shuttering elements or blocks of insulating materials and sometimes concrete", edition June 2002.

The ETA is issued for the shuttering kit "EUROMAC 2" on the basis of agreed information, deposited with Deutsches Institut für Bautechnik (DIBt), which identifies the shuttering kit that has been assessed and evaluated. Changes to the production process, the kit or the components which could result in this deposited information being incorrect, shall be notified to DIBt before the changes are introduced. DIBt will decide whether or not such changes affect the ETA and consequently the validity of the CE marking on the basis of the ETA, and, if so, whether further assessment and/or alterations to the ETA shall be necessary.

2.2.2 ER 1 Mechanical resistance and stability

2.2.2.1 Resulting structural pattern

In end use conditions walls made with shuttering elements "EUROMAC 2" are walls of continuous type according to ETAG 009, paragraph 2.2.

2.2.2.2 Efficiency of filling

Considering the instructions of chapter 4.2 and the installation guide of the ETA applicant the efficient filling without bursting of the shuttering and without voids or any uncovered reinforcement in the concrete core is possible.

The requirements according to ETAG 009, chapter 6.1.2 are met satisfactory.

2.2.2.3 Possibility of steel reinforcement

The instructions in the installation guide of the ETA applicant are appropriate to install steel reinforcement for walls according to EN 1992-1-1 or corresponding national rules.

The requirements according to ETAG 009, chapter 6.1.3 are met satisfactory.

2.2.3 ER 2 Safety in case of fire

2.2.3.1 Reaction to fire

Euroclass F, no performance determined

2.2.3.2 Resistance to fire

Since the minimum thickness of the continuous concrete core can be rounded up to 150 mm the fire resistance class of walls with a minimum concrete strength C16/20 according to Table 1 of Annex C of ETAG 009 is REI 120.

2.2.4 ER 3 Hygiene, health and the environment

2.2.4.1 Release of dangerous substances

According to the manufacturer's declaration the shuttering elements "EUROMAC 2" taking account of the EU database⁸ does not contain any dangerous substances.

In addition to the specific clauses relating to dangerous substances contained in this European Technical Approval, there may be other requirements applicable to the products falling within its scope (e.g. transposed European legislation and national laws, regulations and administrative provisions). In order to meet the provisions of the EC Construction Products Directive, these requirements need also to be complied with, when and where they apply.

⁸ Notes are stated in Guidance Paper H: "A harmonized approach relating to dangerous substances under the Construction Products Directive", Brussels, 18 February 2000

2.2.4.2 Water vapour permeability

The tabulated design value of water vapour diffusion resistance coefficient of expanded polystyrene (EPS), according to EN 12524⁹, is $\mu = 60$.

The values for the water vapour diffusion resistance of concrete in dependence of density and type are tabulated in EN 12524.

2.2.5 ER 4 Safety in use

2.2.5.1 Bond strength between the shuttering leaves and the concrete core

The expanded polystyrene is bonded to the concrete by mechanical interlocking of the dovetail sections running vertically in the inner surfaces of the shuttering leaves over the whole element height with a horizontal distance of 5 cm. Since the width of the dovetail sections is 15 mm the effective area for transmission of tensile forces is $0,015 \cdot 1,20 \text{ m}^2 = 0,3 \text{ m}^2$. This is more than 20 % of the whole area of the shuttering leaves and leads to the effective bond strength of $0,03 \text{ N/mm}^2$ what is sufficient to meet the requirements in ETAG 004, chapter 6.1.4.1.3.

The requirements according to ETAG 009, chapter 6.4.1.3 are met satisfactory.

2.2.5.2 Resistance to filling pressure

The resistance to filling pressure have been determined by testing of the finished shuttering elements with a pneumatic jack. The material for the shuttering leaves was in accordance with 2.1.1. The minimum value of this failure pressure was at $0,09 \text{ N/mm}^2$.

The requirements according to ETAG 009, chapter 6.4.2 are met satisfactory.

2.2.5.3 Safety against personal injury by contact

As delivered on site the shuttering elements do not have sharp or cutting edges. At door or window openings some elements may have to be curtailed. Immediately after cutting the elements the plastic capsule has to be put over the cutting edges of the flat steels.

Because of the soft surface of the shuttering leaves there is no risk of abrasion or of cutting to people.

The requirements according to ETAG 009, chapter 6.4.3 are met satisfactory.

2.2.6 ER 5 Protection against noise

2.2.6.1 Airborne sound Insulation

The "No performance determined" option in ETAG 009, Table 3 is used.

2.2.6.2 Sound absorption

The "No performance determined" option in ETAG 009, Table 3 is used.

2.2.7 ER 6 Energy economy and heat retention

2.2.7.1 Thermal resistance

The nominal value of the thermal resistance R ($\lambda_d = 0,0329 \text{ W/(m}\cdot\text{K)}$ for the expanded polystyrene) of the elements in end use conditions (with concrete infill) is calculated in accordance with EN ISO 6946¹⁰ from the nominal value of the thermal resistance of the shuttering leaves R_{DI} according to EN 13163, chapter 4.2.1, and the thermal resistance of the concrete core R_{DC} (can be calculated by using the values of thermal conductivity in dependence on density tabulated in EN 12524).

$$R = R_{DI} + R_{DC} - \Delta R \quad [\text{m}^2\text{K/W}]$$

⁹ EN 12524:2000 Building materials and products - Hygrothermal properties - Tabulated design values

¹⁰ EN ISO 6946:1996 Building components and building elements - Thermal resistance and thermal transmittance - Calculation method

Because of the influence of the steel ladders this value has to be reduced in dependence of the cross section of the wall as given in the following Table.

Type of shuttering element according to Annex 1	Thickness of the internal shuttering leaf (mm)	Thickness of Concrete core (mm)	Thickness of the external shuttering leaf (mm)	Total thickness (mm)	Reduction of the thermal resistance of the wall $\frac{\Delta R}{R_{DI} + R_{DC}} * 100$ caused by the structure of the shuttering leaves and the influence of the ladders [%]
M 121	45	210	45	300	12
Jumbo M175, M20, M100, PM 100	45	160	45	250	12
Jumbo M175+1, M20+1, M100+1	45	160	95	300	8
Jumbo M175+2, M20+2, M100+2	45	160	145	350	6
Jumbo M175+3, M20+3, M100+3	45	160	195	400	4,5
Jumbo M175+4, M20+4, M100+4	45	160	245	450	4

2.2.7.2 Thermal inertia

The values for heat capacity of concrete and expanded polystyrene are tabulated in EN 12524.

2.2.8 Aspects of durability and servicability

2.2.8.1 Resistance to deterioration

Physical agent

As given in the designation code of the EPS material used (see 2.1.1) the dimensions of the shuttering leaves do not differ more than 3 % after exposing them for 48 h at 70 °C (DS(70,-)3).

The requirements according to ETAG 009, chapter 6.7.1.1 are met satisfactory.

Chemical agent

During construction the plastic capsule according to Annex 3 are to protect the cutting edges of the flat steels from corrosion. The ladders made of steel are only necessary for the resistance to concrete pressure. After hardening of the concrete the bond between concrete and shuttering leaves is given by the dovetail sections running vertically on the inner surfaces of shuttering leaves (see 2.2.5.1).

Therefore the requirement "corrosion protection" according to ETAG 009, chapter 6.7.1.2 is met satisfactory.

Biological agent

The application of EPS as thermal insulating material for decades has shown that it sufficiently protects against fungi, bacteria, algae and insects.

EPS does not provide a food value and in general it does not contain voids suitable for habitation by vermin.

The requirements according to ETAG 009, chapter 6.7.1.3 are met satisfactory.

2.2.8.2 Resistance to normal use damage

Incorporation of ducts

The instructions in the installation guide of the ETA applicant are appropriate to produce horizontal perforations through the walls, which are necessary for the passing through ducts.

Fixing of objects

Fixing of objects in the shuttering leaves is not possible; the part of fixings which is significant for the mechanical resistance shall be in the concrete core.

3 Evaluation and attestation of conformity and CE marking

3.1 System of attestation of conformity

According to the Decision 98/279/EC of 5 December 1997¹¹ amended by the decision 2001/596/EC of the European Commission¹² system 2+ of the attestation of conformity applies.

System 2+: Declaration of conformity of the product by the manufacturer on the basis of:

- (a) Tasks for the manufacturer:
 - (1) initial type-testing of the product;
 - (2) factory production control;
 - (3) testing of samples taken at the factory in accordance with a prescribed test plan.
- (b) Tasks for the approved body:
 - (4) certification of factory production control on the basis of:
 - initial inspection of factory and of factory production control;
 - continuous surveillance, assessment and approval of factory production control.

Note: Approved bodies are also referred to as "notified bodies".

3.2 Responsibilities

3.2.1 Tasks for the manufacturer

3.2.1.1 Factory production control

The manufacturer shall exercise permanent internal control of production. All the elements, requirements and provisions adopted by the manufacturer shall be documented in a systematic manner in the form of written policies and procedures, including records of results performed. This production control system shall insure that the product is in conformity with this European technical approval.

The manufacturer may only use raw materials stated in the technical documentation of this European technical approval.

The factory production control shall be in accordance with the revised control plan of 10 May 2010 which is part of the technical documentation of this European technical approval. The control plan is laid down in the context of the factory production control system operated by the manufacturer and deposited with Deutsches Institut für Bautechnik.¹³

The results of factory production control shall be recorded and evaluated in accordance with the provisions of the control plan.

¹¹ Official Journal of the European Communities L /127 of 24. April 1998

¹² Official Journal of the European Communities L /209 of 8 January 2001

¹³ The "control plan" is a confidential part of the European technical approval and only handed over to the approved body involved in the procedure of attestation of conformity. See section 3.2.2.

3.2.1.2 Other tasks for the manufacturer

The manufacturer shall, on the basis of a contract, involve a body which is approved for the tasks referred to in section 3.1 in the field of non-load bearing shuttering systems in order to undertake the actions laid down in section 3.2.2. For this purpose, the control plan referred to in sections 3.2.1.1 and 3.2.2 shall be handed over by the manufacturer to the approved body involved.

The manufacturer shall make a declaration of conformity, stating that the construction product is in conformity with the provisions of the European technical approval ETA-05/0001 issued on 16 February 2005.

3.2.2 Tasks for the approved body

The approved body shall perform the

- initial inspection of factory and of factory production control,
 - continuous surveillance, assessment and approval of factory production control,
- in accordance with the provisions laid down in the control plan.

The frequency of the inspections by the approved bodies shall be performed in accordance with section II of control plan.

The approved body shall retain the essential points of its actions referred to above and state the results obtained and conclusions drawn in a written report.

The approved certification body involved by the manufacturer shall issue an EC certificate of conformity of the factory production control stating the conformity with the provisions of this European technical approval.

In cases where the provisions of the European technical approval and its control plan are no longer fulfilled the certification body shall withdraw the certificate of conformity and inform Deutsches Institut für Bautechnik without delay.

3.3 CE marking

The CE marking shall be affixed on every second shuttering element and furthermore always on packing and on the accompanying commercial documents. The letters "CE" shall be followed by the identification number of the approved certification body, where relevant, and be accompanied by the following additional information:

- the name and address of the producer (legal entity responsible for the manufacture),
- the last two digits of the year in which the CE marking was affixed,
- the number of the EC certificate for the factory production control,
- the number of the European technical approval ETA-05/0001,
- the number of the guideline ETAG 009 for European technical approval,
- Class F according to EN 13501-1,
- Protection against noise "no performance determined",
- the nominal value of thermal resistance R of the shuttering elements with concrete infill, see ETA.

4 Assumptions under which the fitness of the product for the intended use was favourably assessed

4.1 Manufacturing

The European technical approval is issued for the product on the basis of agreed data/information, deposited with Deutsches Institut für Bautechnik, which identifies the product that has been assessed and judged. Changes to the product or production process, which could result in this deposited data/information being incorrect, should be notified to Deutsches Institut für Bautechnik before the changes are introduced. Deutsches Institut für Bautechnik will decide whether or not such changes affect the approval and consequently the validity of the CE marking on the basis of the approval and if so whether further assessment or alterations to the approval shall be necessary.

4.2 Installation

4.2.1 General

The manufacturer shall ensure that the requirements in accordance with sections 1, 2, and 4 are made known to those involved in planning and execution. The installation guide is deposited at DIBt and shall be present at every construction site. If the manufacturer's instructions contain provisions which differ from those stated here, the specifications of the ETA shall apply.

After installation of the shuttering elements (see 4.2.2) the site-mixed or ready mixed concrete is brought in and compacted.

In end use conditions concrete walls of continuous type¹⁴ of plain or reinforced concrete according to EN 1992-1-1 or corresponding national rules will be formed.

For structural design dimensions and weights given in Annex 8 have to be used.

In end use conditions the EPS-shuttering leaves are the main part of the thermal insulation of the walls.

4.2.2 Installation of the shuttering elements

The shuttering elements are put together on site in layers joint mortar or adhesive. To receive stable floor high formworks the vertical joints between two elements of one layer have to be shifted of at least a quarter of the element length to the vertical joints of the previous and next layer (see Annex 4).

First of all two layers of the entire floor plan are to be interlocked according to the installation guide of the manufacturer.

Afterwards leveling to the subsoil is performed (foundation, bottom plate, ceiling). Voids between the shuttering leaves and the uneven subsoil are to be sealed with PU foam before concreting.

Subsequently, according to the installation guide of the manufacturer, the walls are to be interlocked to floor height, leveled and fastened to the scaffolding supports.

The scaffolding supports are to be arranged at a distance of 1.20 m to 1.50 m at the most, to be connected over the entire wall height with the shuttering elements and to be fastened to the floor. Cut sections of flat steels which are visible after cutting the elements at the door and window openings are to be covered with plastic capsule according to Annex 8.

¹⁴ see ETAG 009 chapter 2.2

The necessary reinforcement according to the structural analysis shall also be installed in an appropriate way. Rectangular wall corners are to be formed according to Annex 5, wall junctions according to Annex 6 and wall corners of arbitrary angle according to Annex 7,

4.2.3 Concreting

For the production of normal concrete EN 206-1:2001-07 shall apply. The consistency of concrete on compacting by shaking shall be within the lower consistency range F3 and on compacting by poking within the upper consistency range F3. The maximum aggregate size shall be at least 8 mm and shall not exceed 16 mm. The concrete shall have rapid or middle strength development according to EN 206-1:2001-07, Table 12.

Placing the concrete shall be performed only by persons who were instructed in the works and in the proper handling of the shuttering system.

The maximum filling height amounts to 1 m at a concreting velocity of 3 m/h.

If equivalent national rules are not available the following instructions shall be considered:

Horizontal day joints are to be arranged preferably at the height of the floor. In the case these can not be avoided vertical composite reinforcement bars has to be installed. The composite reinforcement shall comply the following requirements:

- two adjacent composite reinforcement bars shall not be situated in the same plane parallel to the surface of the wall,
- the distance between two composite reinforcement bars in wall direction shall be at least 10 cm and not larger than 50 cm,
- the total section area of the composite reinforcement bars shall not be minor than 1/2000 of the section area of the concrete,
- anchorage length of the composite reinforcement bars on both sides of the day joint at least shall be 20 cm

Before the further placing of concrete, cement laitance and detached / loose concrete shall be removed and the day joints shall be sufficiently pre-wetted. At the time of concreting the surface of the older concrete shall be slightly moist, so that the cement paste of the newly brought in concrete can combine well with the older concrete.

If no day joint is planned, placing of concrete in layers may only be interrupted if the concrete layer brought in last has not yet solidified so that a good and even bond is still possible between the two concrete layers. When using internal vibrators the vibrating cylinder shall still penetrate into the already compacted lower concrete layer.

The concrete may fall freely only up to a height of 2 m, beyond that the concrete shall be cohered by discharge pipes or concreting tubes with a diameter of 100 mm at the most and shall be led shortly before the place of installation.

Cones from pouring are to be avoided by short distances of the places of fill in.

Planning shall allow for sufficient spaces in the reinforcement for discharge pipes or concreting tubes.

After concreting the walls may not deviate from the plumb line more than 5 mm per running meter wall height.

The ceiling may only be placed on walls made of shuttering elements if a sufficient strength of the concrete core exists.

4.2.4 Ducts crossing and situated inside the wall

Horizontally passing ducts are to be installed according to the installation guide of the ETA applicant and are to be taken into account when designing the wall.

Horizontal ducts situated inside the wall cores are to be avoided. If absolutely necessary, these are to be taken into account when designing the wall.

Also vertical ducts in the concrete core shall be considered, if their diameter exceeds 1/6 of the thickness of the concrete core and the distance of the pipes is less than 2 m.

4.2.5 Reworking and finishes

Walls of the type "EUROMAC 2" are to be protected by finishes. Finishes are not part of the kit and therefore not considered in this ETA. Preferably for external surfaces the used rendering systems should meet the requirement of ETAG 004¹⁵. The execution of the rendering shall be performed according to applicable national rules.

4.2.6 Fixing of objects

Fixing of objects in the shuttering leaves is not possible; the part of fixings which is significant for the mechanical resistance shall be in the concrete. The influence of the fixing to the reduction of the thermal resistance has to be considered according to EN ISO 6946.

5 Indications to the manufacturer

5.1 Packaging, transport and storage

The shuttering elements have to be protected against damage, soiling and intensive action of water during transport and storage. If necessary the elements has to be covered.

5.2 Use, maintenance, repair

Regular checks should be carried out on render finishes to ensure that any damage is detected and repaired as soon as possible.

The recommendations on use, maintenance and repair in ETAG 009, section 7.5 shall be considered.

Dipl.-Ing. Georg Feistel
Head of Division Construction Engineering
of Deutsches Institut für Bautechnik
Berlin, 10 May 2010

beglaubigt:
Schwab

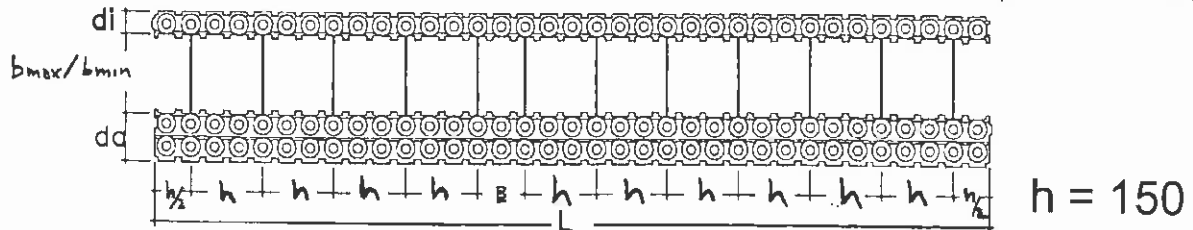
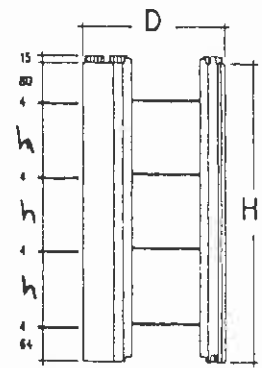

Type	L	H	D	d_a	b_{max}	b_{min}	d_i
JUMBO M175	1750	600	250	45	160	145	45
JUMBO M175+1	1750	600	300	95	160	145	45
JUMBO M175+2	1750	600	350	145	160	145	45
JUMBO M175+3	1750	600	400	195	160	145	45
JUMBO M175+3	1750	600	450	245	160	145	45
M20	1750	200	250	45	160	145	45
M20+1	1750	200	300	95	160	145	45
M20+2	1750	200	350	145	160	145	45
M20+3	1750	200	400	195	160	145	45
M20+4	1750	200	450	245	160	145	45
M100	1000	300	250	45	160	145	45
M100+1	1000	300	300	95	160	145	45
M100+2	1000	300	350	145	160	145	45
M100+3	1000	300	400	195	160	145	45
M100+4	1000	300	450	245	160	145	45
M121	1000	300	300	45	210	195	45
PM100	1000	300	250	45	160	145	45

all dimensions in mm

EUROMAC 2	Annex 1 of European Technical Approval ETA – 05/0001
Normal (standard) shuttering elements	

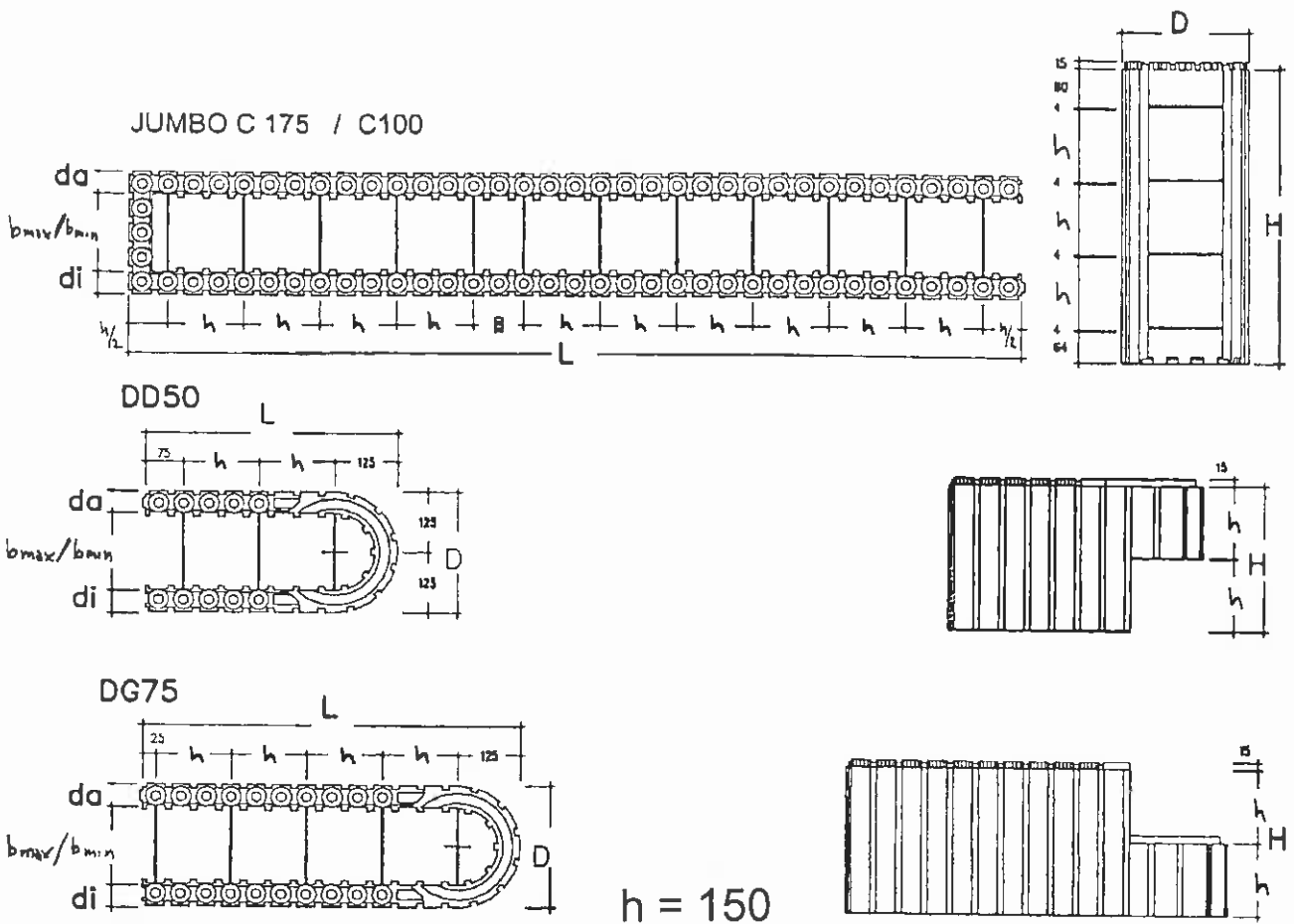

Type	L	H	D	d_a	b_{max}	b_{min}	d_i
JUMBO C175	1750	600	250	45	160	145	45
DD50	500	300	250	45	160	145	45
DG75	750	300	250	45	160	145	45
C100	1000	300	250	45	160	145	45

all dimensions in mm

EUROMAC 2	Annex 2 of European Technical Approval ETA – 05/0001
Special shuttering elements	

end leaf 16

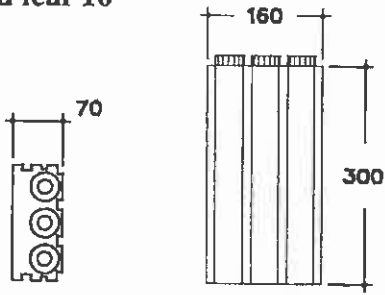

end leaf 21

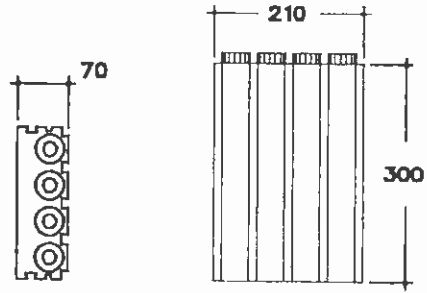

end leaves

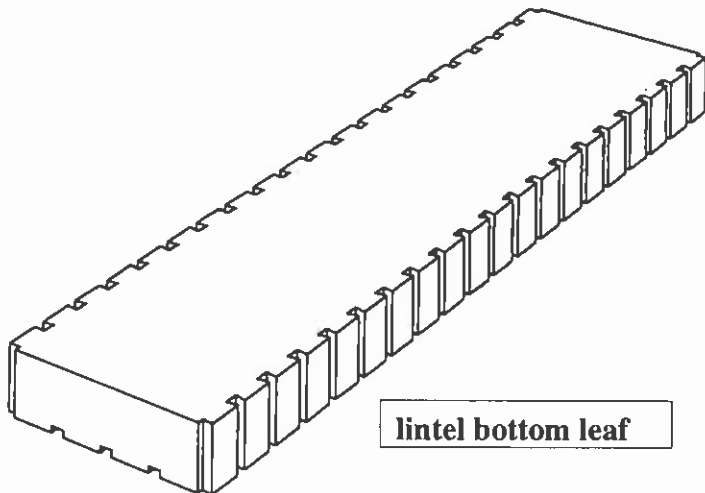
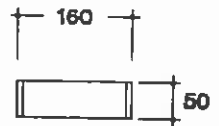
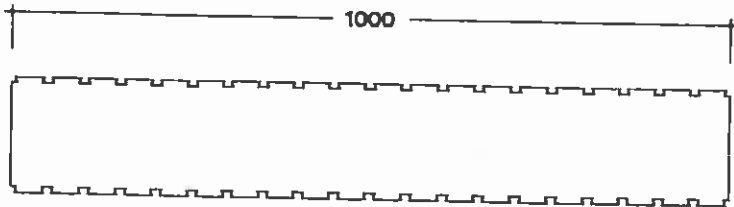

lintel bottom leaf

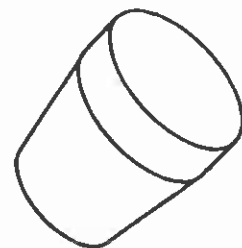

capsule

all dimensions in mm

EUROMAC 2

Accessory parts
 (end elements, lintel element, capsule)

Annex 3
 European
 Technical Approval

ETA - 05/0001

1st layer

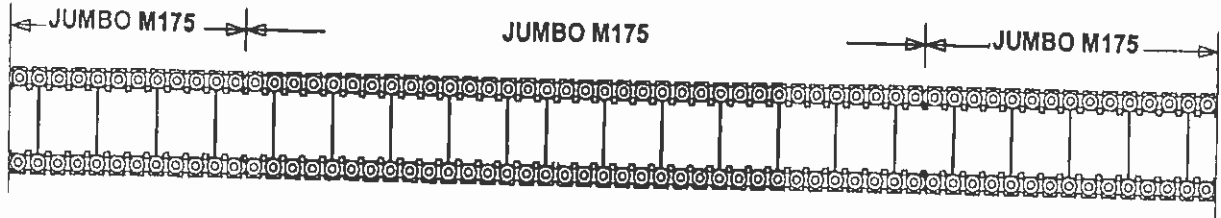

2nd layer

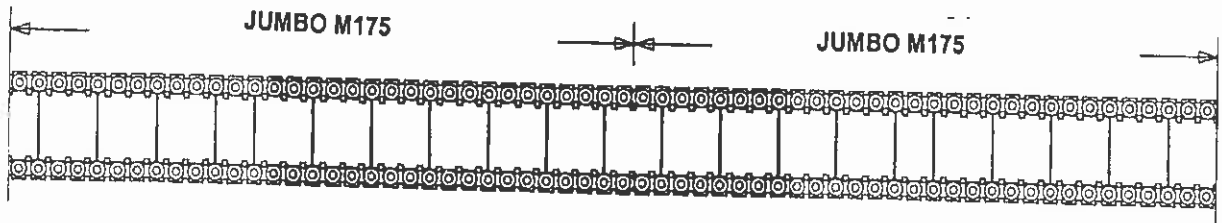

EUROMAC 2

Structure of layer on a straight wall

Annex 4
of European
Technical Approval

ETA – 05/0001

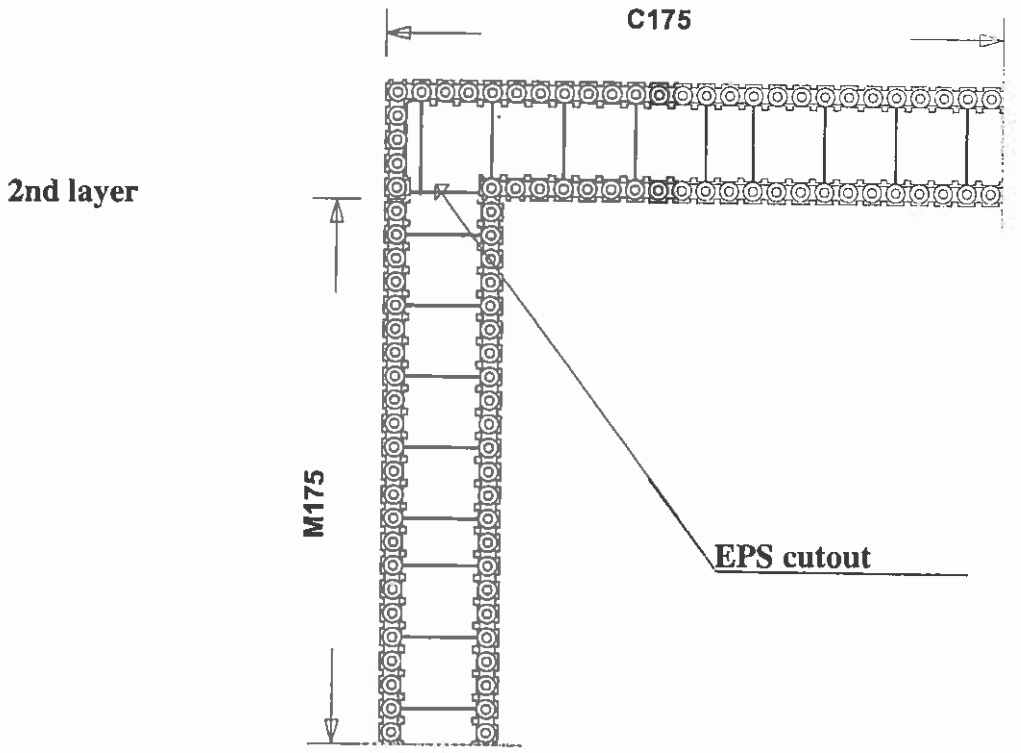
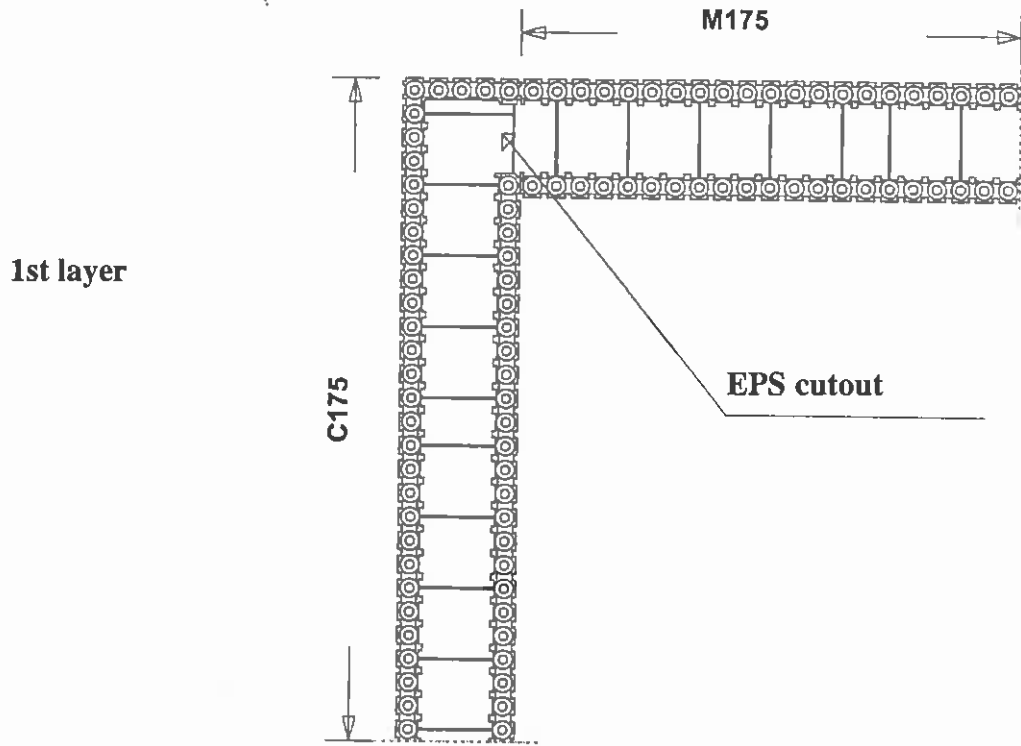

EUROMAC 2

Structure of layer on a rectangular wall corner

Annex 5
of European
Technical Approval

ETA - 05/0001

1st layer

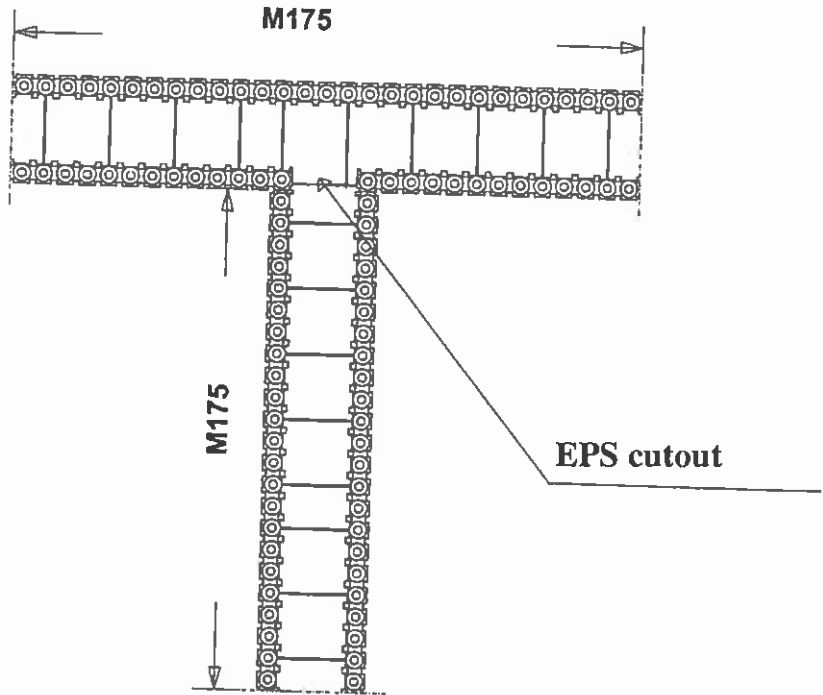

2nd layer

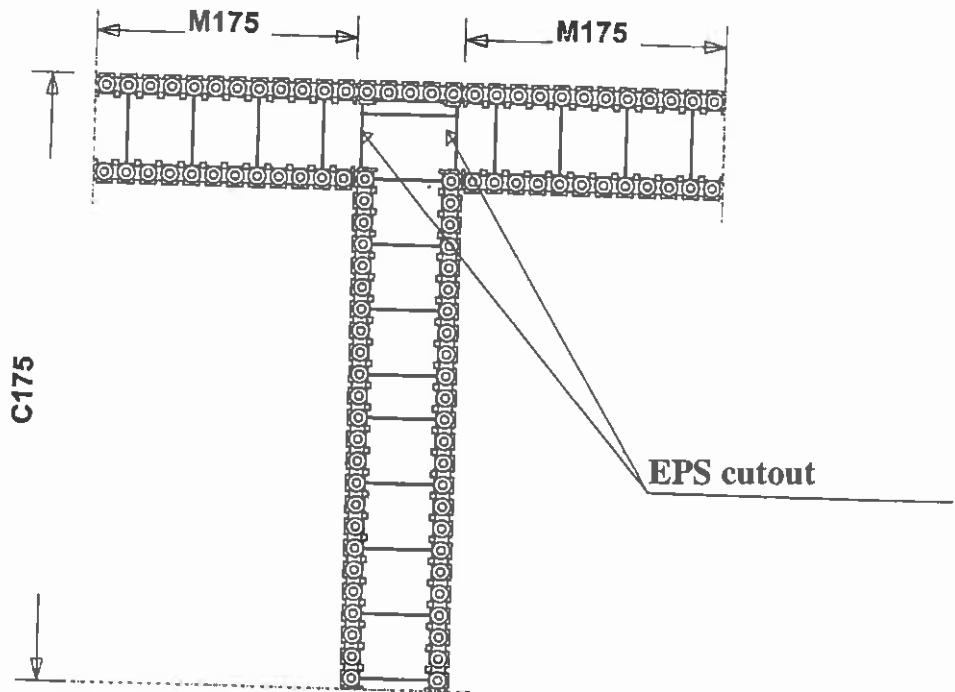

EUROMAC 2

Structure of layer at wall junctions

Annex 6
of European
Technical Approval

ETA – 05/0001

1st layer

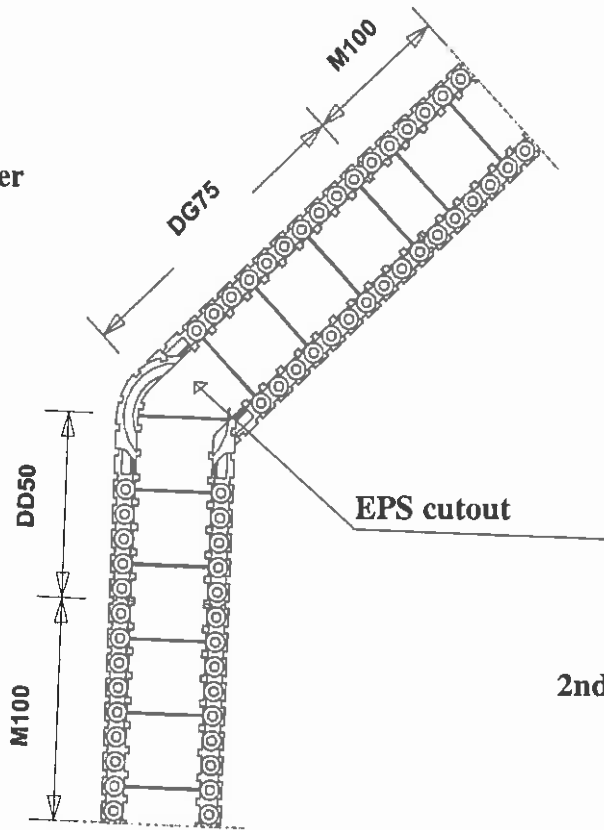

2nd layer

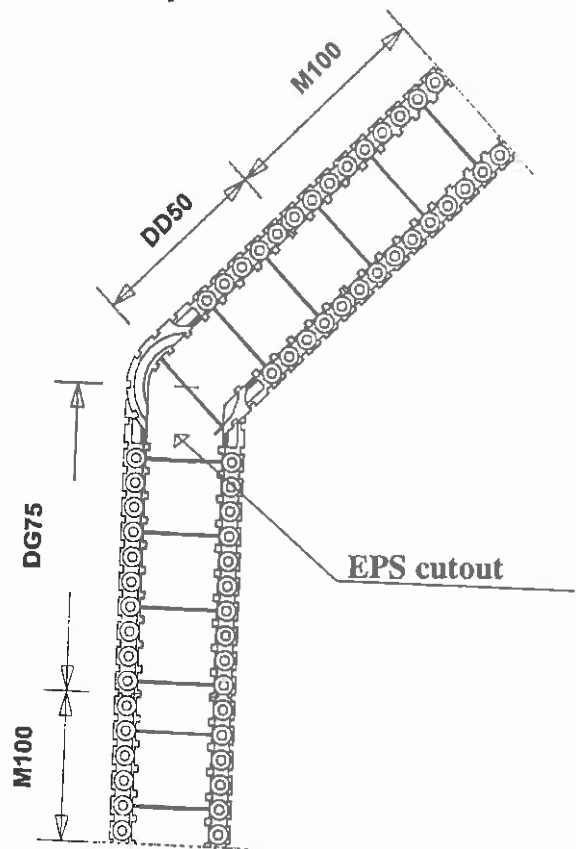

EUROMAC 2

Structure of layer at wall corners of arbitrary angle

Annex 7
 of European
 Technical Approval

ETA - 05/0001

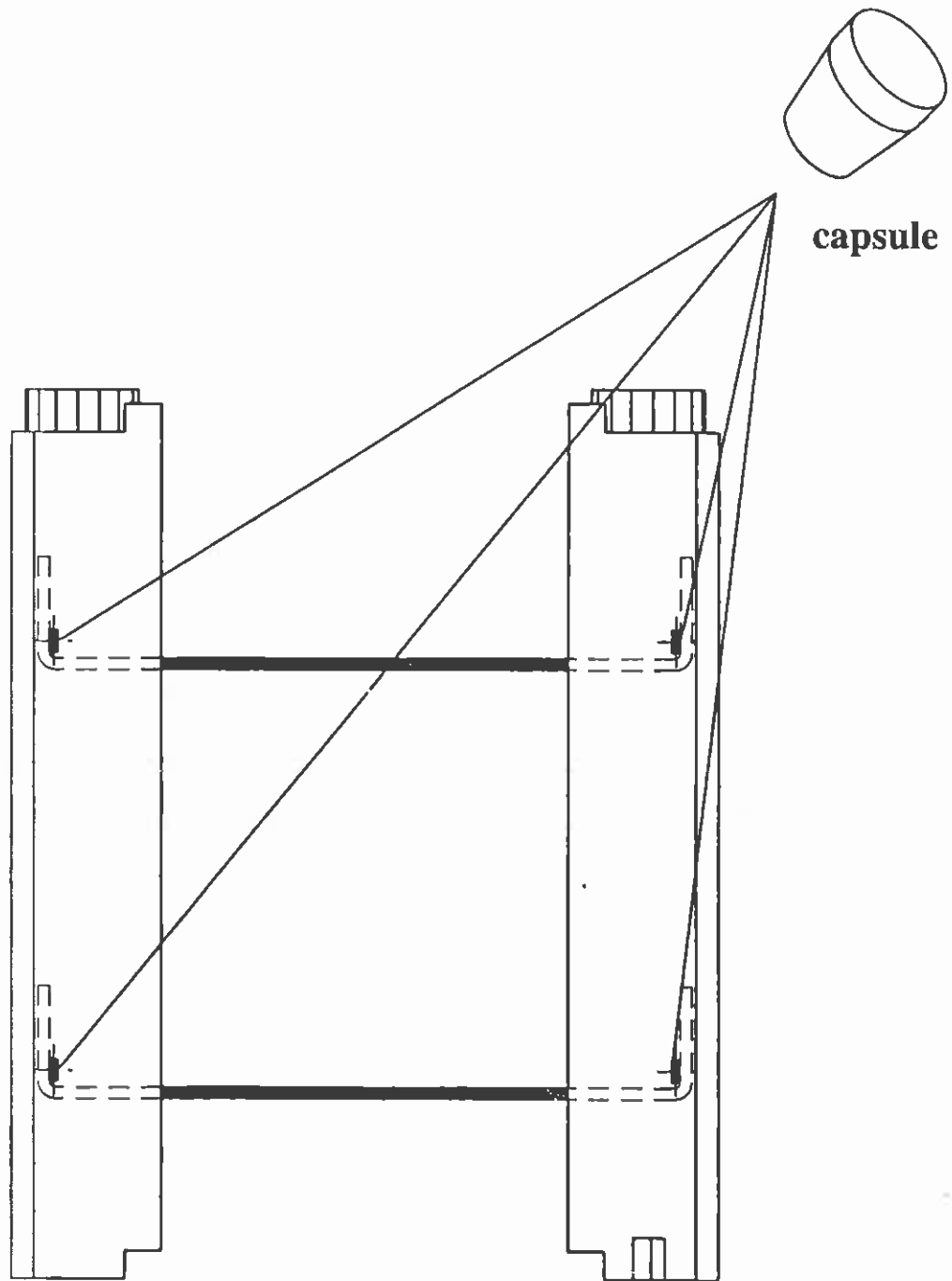

Plastic capsule to cover the flat steels of the ladders on cutting edges

EUROMAC 2

Plastic capsule

Annex 8
of European
Technical Approval

ETA - 05/0001

TYPE	according to Annex	g wall thickness	average thickness of concrete core	core area m ² /m	volume of concrete core m ³ /m ²	calculation weight of shuttering elements without rendering kN/m ²	weight of wall filled with concrete kN/m ²
JUMBO C 175	2	25	0.155	0.155	0.155	0.065	3.94
JUMBO M 175	1	25	0.155	0.155	0.155	0.065	3.94
JUMBO M 175+1	1	30	0.155	0.155	0.155	0.08	3.96
JUMBO M 175+2	1	35	0.155	0.155	0.155	0.095	3.97
JUMBO M 175+3	1	40	0.155	0.155	0.155	0.11	3.99
JUMBO M 175+4	1	45	0.155	0.155	0.155	0.125	4.00
JUMBO M 20	1	25	0.155	0.155	0.155	0.065	3.94
JUMBO M 20+1	1	30	0.155	0.155	0.155	0.08	3.96
JUMBO M 20+2	1	35	0.155	0.155	0.155	0.095	3.97
JUMBO M 20+3	1	40	0.155	0.155	0.155	0.11	3.99
JUMBO M 20+4	1	45	0.155	0.155	0.155	0.125	4.00
M100	1	25	0.155	0.155	0.155	0.065	3.94
M100+1	1	30	0.155	0.155	0.155	0.08	3.96
M100+2	1	35	0.155	0.155	0.155	0.095	3.97
M100+3	1	40	0.155	0.155	0.155	0.11	3.99
M100+4	1	45	0.155	0.155	0.155	0.125	4.00
C100	2	25	0.155	0.155	0.155	0.065	3.94
M121	1	30	0.205	0.205	0.205	0.065	3.94
PM100	1	25	0.155	0.155	0.155	0.065	3.94
DG75	2	25	0.155	0.155	0.155	0.065	3.94
DD50	2	25	0.155	0.155	0.155	0.065	3.94
DS50	2	25	0.155	0.155	0.155	0.065	3.94

EUROMAC 2

Dimensions and weights for the structural design
 (Weights has determined with a specific gravity
 of 25 kN/m³ for concrete)

Annex 9

of European
 Technical Approval

ETA – 05/0001